

626EL Automatic USB Electric Stapler

Operating Instructions

Please read the following instructions carefully before operating your stapler

To be used under adult supervision only

Connecting your Stapler

This automatic stapler will operate using either batteries (not included) or via a USB port (cable included).

To operate using the USB cable, insert the connector into the rear of the stapler marked "USB". Insert the USB socket preferably into a mains USB plug or alternatively into your computer USB port.

PLEASE NOTE: If the stapler is connected to a computer USB port, the power may not be as efficient to fully power the stapler as it would be if the USB was connected to a mains power outlet.

Using the Stapler

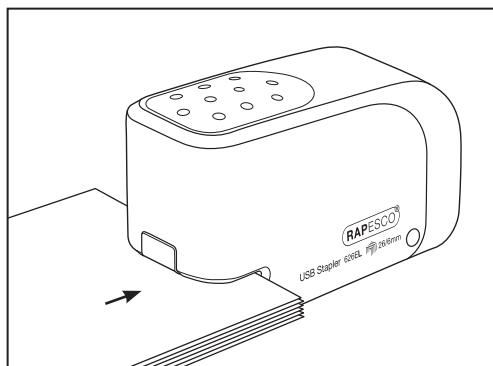

1. Ensure the stapler is placed on a stable, rigid surface before inserting any papers.
2. To activate the stapler, simply insert the paper (max. 15 sheets) into the opening at the front of the stapler. Stapling will begin automatically when paper is inserted.

Dimensions	Weight	Compatible Staples	Capacity
L 131 x W 52 x H 84mm	280g	26/6mm	Max. 15 sheets (80gsm)

Installing Batteries

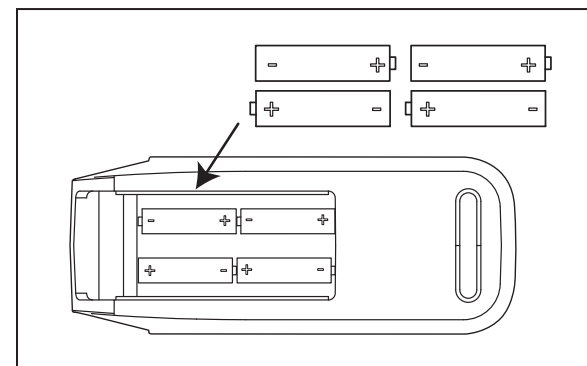

1. Open the battery compartment on the bottom of the stapler.
2. Insert four new AA (1.5V) alkaline or rechargeable batteries into the compartment according to the diagram making sure to observe correct polarity.
3. Close battery compartment.

Loading Staples

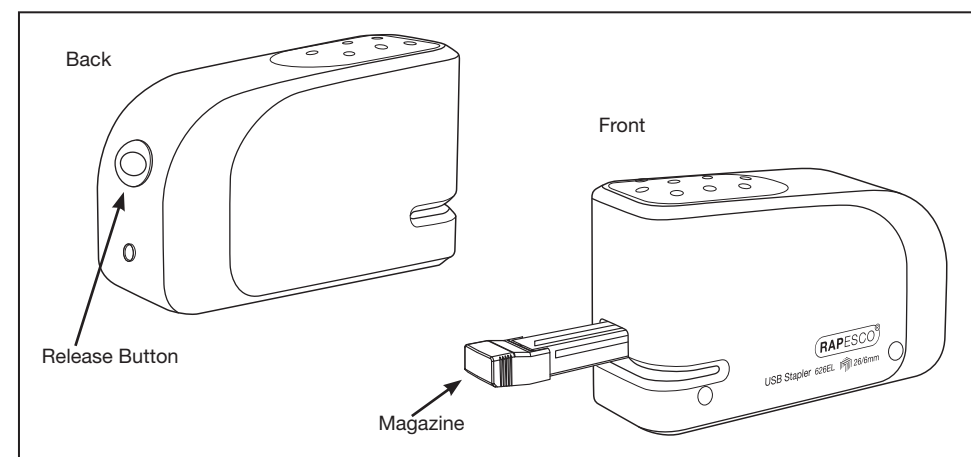

1. Ensure there is no paper in the stapling mouth before adding more staples.
2. Press the button at the rear of the stapler to eject the staple magazine channel.
3. Load Rapesco 26/ 6mm staples into the staple channel before gently pushing it back into the stapler until it clicks into place.

Avoiding Paper Jams

1. A staple jam will occur when the sheet capacity is exceeded. **DO NOT** staple more than 15 sheets (80gsm) at any one time.
2. Between each staple allow the stapler motor to fully complete its cycle before removing the paper from the stapling mouth.
3. **DO NOT** continue stapling if the batteries appear flat.

Clearing Paper Jams

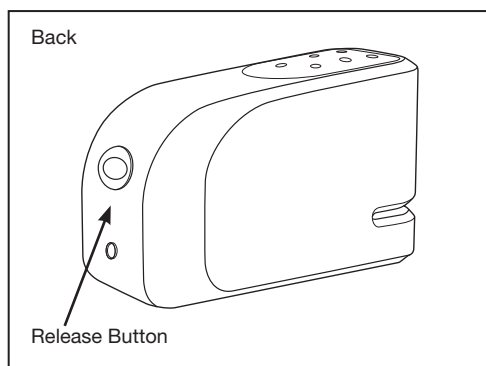

1. Should your stapler jam **DO NOT** pull at the paper in the stapler mouth before following steps 2 & 3 otherwise you will damage the motor and the stapler.
2. If paper is stuck, remove the power source (USB cable or batteries), then press the button at the rear of the stapler to eject the staple magazine channel.
3. Gently pull the channel out fully and remove the jammed paper and staple.
4. Ensure the staples are correctly loaded before pushing the magazine channel back into place.
5. Add/ re-connect your power source again to continue stapling.

Tips & Warnings

1. Pulling any paper out too quickly or with force will damage the stapler motor as the movement mechanism is designed to complete a full cycle each time.
2. **DO NOT** drop the stapler as this will damage the internal working parts.
3. **DO NOT** mix old and new batteries, always replace all 4 batteries at the same time.
4. **DO NOT** mix alkaline or rechargeable batteries due to risk of explosion, all 4 batteries must be the same type.
5. To avoid damage from battery leakage, remove batteries when stapler is not used for long periods.
6. As with all electrical appliances, keep out of the reach of small children.
7. This stapler is for paper only so do not insert any other objects or material into the stapler.
8. The supplied USB cable is only compatible with USB 2.0 Type A connectors.
9. Warning – this is **NOT** a toy.

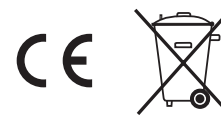

Do not dispose of electrical appliances as unsorted municipal waste, use separate collection facilities.

Contact your local government for information regarding the collection systems available.

Rapesco Office Products Plc, Kent UK
Rapesco-Tacwise BV, Netherlands
rapesco.com

Rapesco Office Products PLC, Unit 1 Connections Business Park Otford Road, Sevenoaks, Kent, England TN14 5DF
Rapesco-Tacwise BV, Krajenhoffstraat, 137A, 1018RG Amsterdam, Netherlands.