

## Setting the Diary Punch A5 Diaries

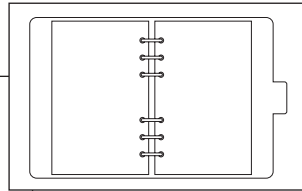

1. Make sure that the punching cutters are set for Personal diary size.
2. Using a ruler, mark 82mm on the punch, working in from the right-hand side.

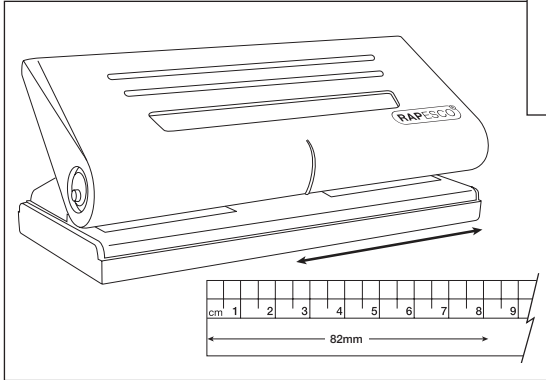
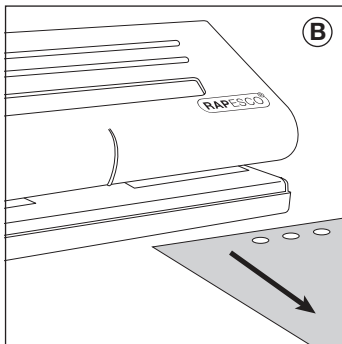
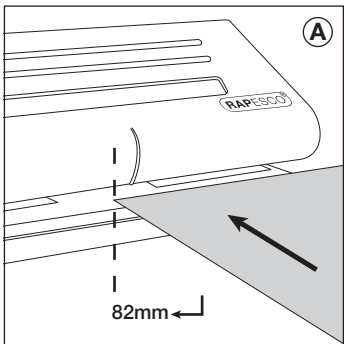

1. Position your A5 paper so that one edge lines up with the mark as shown in **A**.
2. Punch 3 holes and remove the paper from the punch **B**.

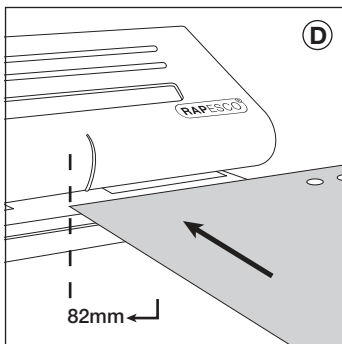
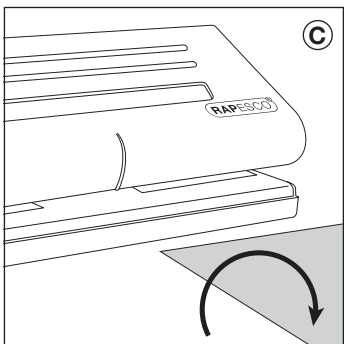

1. Turn the punched paper over **C** and re-position as shown in **A**.
2. Punch 3 more holes as shown in **D**. The punched sheet will now fit an A5 diary.

**NOTE:** When aligning for A5, the centre mark on the punch is not applicable.

## Pocket and Pocket Slim Diaries

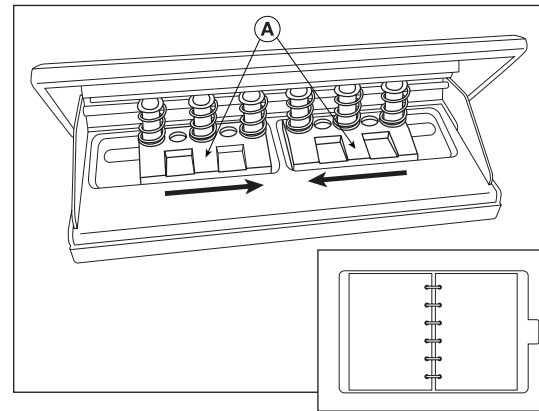

Push the punching cutters **A** together. Your Diary Punch is now set up for Pocket and Pocket Slim diary sizes as shown.

## Personal, Compact and Slimline Diaries

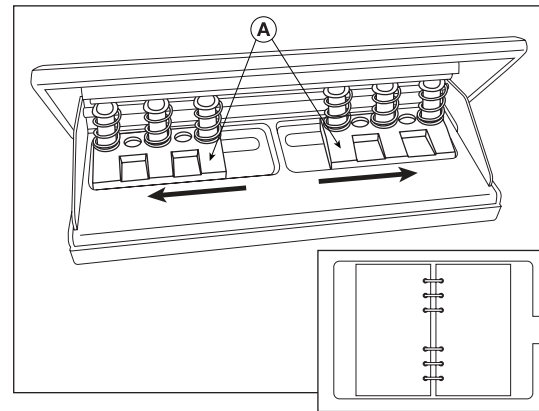

Push the punching cutters **A** apart. Your Diary Punch is now set up for Personal, Compact and Slimline diary sizes as shown.

**NOTE:** On first use the punching cutters will be stiff to move.